

**AGENDA**  
**CITY OF DAYTON, MINNESOTA**  
**12260 S. Diamond Lake Road, Dayton, MN 55327**  
**Tuesday, April 7, 2026**  
**REGULAR MEETING OF THE PARKS COMMISSION: 6:30 P.M.**

**To Participate in the Meeting, Please see [www.daytonmn.gov](http://www.daytonmn.gov) Calendar for Zoom Invitation.**

- 6:30     **CALL TO ORDER**
- PLEDGE OF ALLEGIANCE**
- 6:30     **APPROVAL OF AGENDA**
- 6:30     **CONSENT AGENDA**     *These routine or previously discussed items are enacted with one motion. Minutes can be approved by those absent from meeting.*
- A.    Approval of Park Commission Minutes from March 03, 2026
- 6:35     **OPEN FORUM**     *Limited to 3 minutes for non-agenda items; state your name and address; No action will be taken and items will be referred back to staff and/or Council.*
- COUNCIL UPDATE**
- REGULAR MEETING**
- 7:00            **B.**    Commission Park Tour
- 7:30            **C.**    Date for PCM Goals Meeting with City Council
- 8:00            **D.**    Elsie Stephens Park 3 Update
- 8:30            **E.**    Snow Mobile Trail Connections
- NOTICES AND ANNOUNCEMENTS**
- F.    Next Park Commission Meeting: Tuesday, May 05, 2026
- 9:00     **ADJOURNMENT**

The City of Dayton's mission is to promote a thriving community and to provide residents with a safe and pleasant place to live while preserving our rural character, creating connections to our natural resources, and providing customer service that is efficient, fiscally responsible, and responsive.

**MINUTES OF THE MARCH 3, 2026, PARKS COMMISSION MEETING**  
**CITY OF DAYTON, MINNESOTA**

**CALL TO ORDER**

Pikal called the City of Dayton Parks Commission meeting to order for March 3, 2026.

Present: David Pikal, Luke Senst, Keri Lingard, and Kaia Chambers

Absent: Brad Cole

City Council Member Present: Scott Salonek

Also in attendance: Public Works Superintendent, Marty Farrell; Community Development Director, Jon Sevald

**PLEDGE OF ALLEGIANCE**

**APPROVAL OF AGENDA**

*Motion to approve the proposed agenda by Chambers, seconded by Lingard.*

*Motion carried unanimously.*

**CONSENT AGENDA**

**A. Approval of Park Commission Minutes from February 3, 2026**

*Motion to approve the meeting notes from the February meeting by Lingard, seconded by Senst. Motion carried unanimously.*

**OPEN FORUM**

No members of the public were present to speak.

**COUNCIL UPDATE**

Salonek indicated that his update would be covered during the annual council update discussion later in the meeting. No additional items were presented by Farrell.

**REGULAR MEETING**

**B. Comprehensive Plan and Development Update**

Sevald presented five development projects requiring Parks Commission recommendations for park and trail dedication fees or land dedication. Sevald explained that state statute allows cities to require reasonable portions of buildable land from developers or collect fees instead, which can only be used for land acquisition or park improvements, not maintenance.

*Project 1 - Graco Building:* A three-story building on the west side of French Lake with approximately \$109,000 in park and trail dedication fees. However, the city agreed to a \$200,000 credit toward development fees to encourage Graco to build in Dayton, which would eliminate the park fees. The Diamond Lake Regional Trail already exists adjacent to the project.

*Project 2 – Reserve at Vineyard Meadow:* Residential development with approximately \$88,000 in park dedication fees. Staff recommended easements for future trail construction rather than immediate trail building since connections don't currently exist. The project is within a search area for a community park and adjacent to the planned Holy Spirit Academy.

*Project 3 - Sundance Greens 12th Addition:* An amendment to the planned unit development requiring land dedication for Dayton Farms Park (Area 21 Park), representing the final piece needed to complete this long-planned park.

*Project 4 - Dubai Lake Preserve:* A large concept plan with two options (453-478 lots) generating \$3.3-3.5 million in potential park dedication fees. Staff recommended multiple trail constructions including along 117th Avenue, power line easements, east wetland complex, and around Dubai Lake. The project raises questions about a

future neighborhood park (Area 18) versus a community park in the northwest area, as well as potential civic campus locations.

*Project 5 - Stenslie-Stern:* A concept plan for 172 townhomes along County Road 81 and Territorial Trail with approximately \$1.2 million in park dedication fees. Staff recommended considering land dedication for Area 20 neighborhood park and trail construction along sanitary sewer easements.

*Motion to accept staff recommendations with exceptions that Graco's \$200,000 credit be more evenly distributed across fee types rather than solely from park dedication fees, continued discussion on snowmobile trails for Dubay, and community park versus Area 18 park discussions by Senst, seconded by Lingard. Motion carried unanimously.*

### **C. Elsie Stephens Park Canoe/Kayak Bid Award**

Farrell reported that the City Council approved the bid award to SunRam for \$383,000, significantly under budget. The remaining grant funds will be used at Goodin Park with Three Rivers Park District. Construction is expected to begin late spring/early summer with September 2026 completion.

### **D. 2026 Park Commission Goals Discussion & Annual Council Update**

Farrell facilitated discussion of commission goals and annual council meeting preparation. Key goals identified included:

*Trail Development:* Internal work session to prioritize trail connections and discuss snowmobile trail preservation, plus improving trail information accessibility on the city website and app.

*Community Park Planning:* Work session with City Council after community survey results are available, focusing on location and scope decisions.

*Additional Projects:* Tree City USA initiative continuation, Arbor Day proclamation, Diamond Lake baseball diamond improvements, natural space development, historical walking trail in downtown, memorial bench standardization, and expanded donation options including pavers.

Salonek updated on the Elsie Stephens band shell project has been delayed until fall 2026 due to extended manufacturing lead times (20-24 weeks) that would conflict with summer events. The DNR boat landing construction is planned for 2027.

Commission members discussed frustration with previous proposal rejections, including the \$30,000 parks and recreation facilities study that was voted down 3-2 by City Council. They would like the study revisited by Council. They emphasized the need for better communication and working relationships with the Council.

Lingard added future ideas for natural trails and play area in Goodin Park, using what we have in Dayton, and continuing the giving garden. Farrell agreed it could fit in, but the area often floods and it could be difficult to sustain the trails.

### **NOTICES AND ANNOUNCEMENTS**

The next Parks Commission meeting is scheduled for Tuesday, April 7, 2026.

### **ADJOURNMENT**

*Motion to adjourn the meeting Senst, seconded by Chambers. Motion carried unanimously.*

The meeting was adjourned at 8:09 PM.

**PRESENTER:** Martin Farrell

**ITEM:** Park Commission Park Tour

**PREPARED BY:** Martin Farrell

**POLICY DECISION / ACTION TO BE CONSIDERED:** Select a date and locations for Commission for Park Tour

**BACKGROUND:** The Commission discussed earlier in the year the desire to have a tour of the City Parks.

**CRITICAL ISSUES:** Select a date and locations for Tour

**BUDGET IMPACT:** None

**RECOMMENDATION:** Discussion

**ATTACHMENT(S):** Park Map

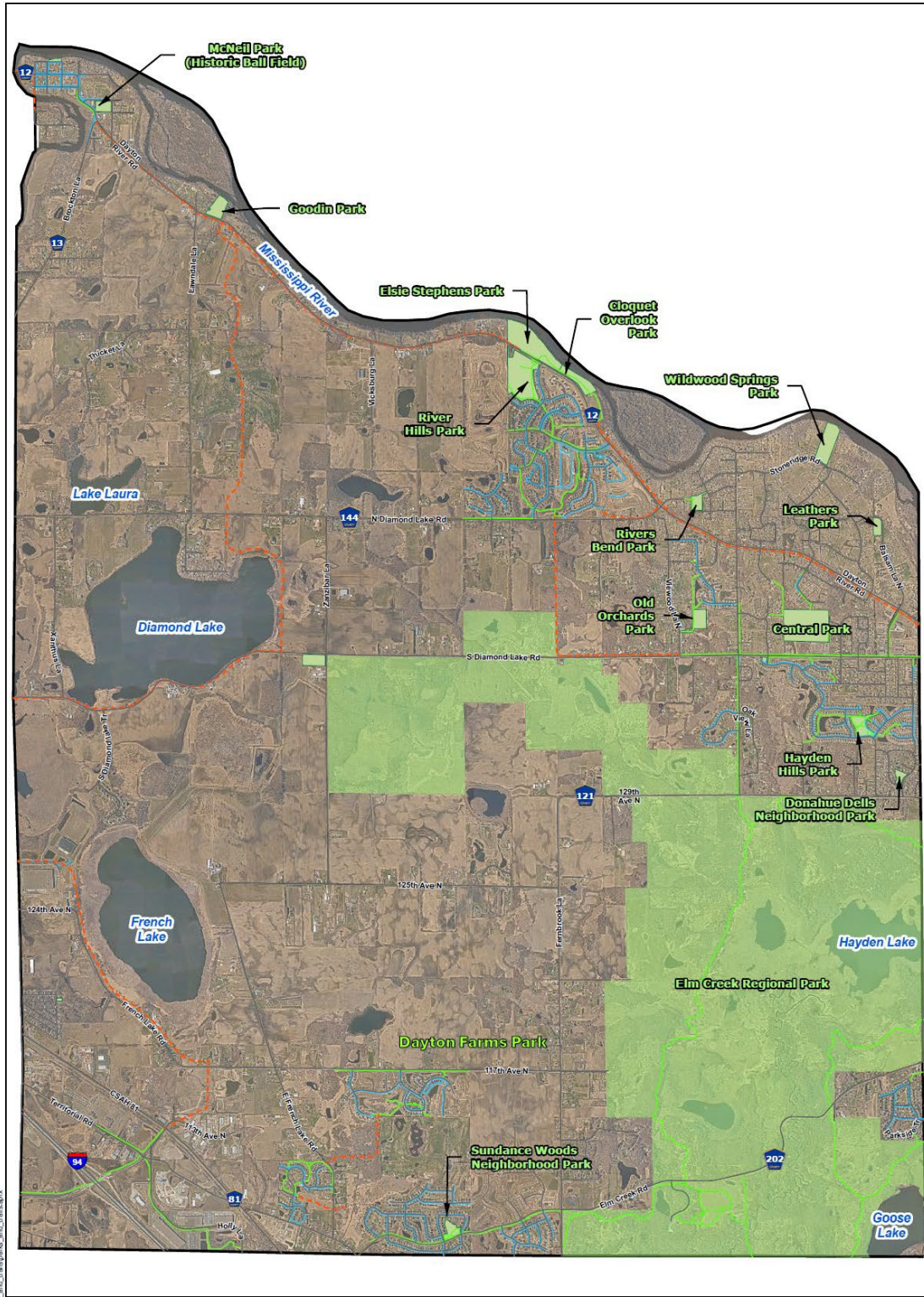

Date: 1/27/2023 10:00 AM; User: jay@dayton.gov; File: Parks\_and\_Trails.aprx



**Legend**

- Sidewalk - Existing
- Trail - Existing
- Trail - Proposed
- Parks
- Elm Creek Regional Park
- Municipal Boundary
- Roads

**PRESENTER:** Marty Farrell

**ITEM:** Park Commission 2025 Project Updates, 2026 Goal Setting & Prioritization, Preparation for Council Update meeting discussion.

**PREPARED BY:** Marty Farrell

**POLICY DECISION / ACTION TO BE CONSIDERED:** None.

**BACKGROUND:** Staff would like guidance from the Park Commissions on their goals for 2026 specifically, and longer-term projects for consideration.

**Park Improvement projects from 2025 status update.**

**Dayton Farms Park**, sport court seal and painting, complete sport court hardware installation, irrigation system completion, tree installation, final completion walk through and acceptance of project.

**Ione Gardens**, landscaping improvements completed, additional trees installed, final completion walk through and acceptance of project.

**Elsie Stephens Canoe/Kayak Launch**, design, permitting and bid documentation completed.

**DNR boat landing reconfiguration**, this project is at the Design and planning stage.

**Elsie Stephens Master Plan Update**, Master Plan is completed and accepted by the City Council.

**Irrigation projects**, Elsie Stephens Park, River Hills play area, Hayden Hills, Ione Gardens and Sundance Woods, all of the irrigation system installations are complete, we have a Spring start up and acceptance of the projects to complete in 2026.

**Replacement trash receptacles**, receptacles have been purchased to replace the existing ones at Cloquet Park, these will be replaced in Spring of 2026.

**Leathers Park:** seeded with Prairie Mix, mowed in Fall, will need overseeding in 2026.

**Park Improvement projects 2026**

**Trash and recycling containers replace/installation**, Central Park

**Install play equipment boxes**, these boxes were funded from a grant with HCYSG, they will contain equipment appropriate to the park that they are located in, anticipated located. Anticipated locations, Central, Riversbend, Sundance Woods, Hayden Hills, River Hills.

**Elsie Stephens Park Phase 3**, this project is being coordinated currently based on Council direction. Currently at design refinement, need to get required permits and complete bid documentation for Bid and build in 2026.

**Elsie Stephens Park entry**, there is funding allocated for signage at the entrance to the Park.

**Elsie Stephens Canoe/Kayak**, bid opening in February 2026 for construction in the Summer of 2026.

**DNR boat landing reconfiguration**, design refinement, bid documentation and permitting expecting to be completed in 2026 with construction in 2027.

**Territorial Road/Rush Creek Parkway trail connection**, trail connection design, bid and construction 2026.

**Diamond Lake Diamonds**, update facility to incorporate soccer fields and improve ball field and parking lot update funding identified \$25,000 over 4 years.

**Trails**, Identify new trail corridors. Identify snow mobile trails.

**Community Park**, discussion with Council.

**Park Commission function**, discussion with Council to understand what City Council thinks the purpose and goals of the Park Commission, and to foster a better relationship with the Council

**Improve GIS interactive map**, improve the user experience for the online interactive map.

**Current fund balances**, Park Dedication \$2,908,909 of this \$1,300,000 is reserved for the community Park, and \$1,500,000 is reserved for Elsie Stephens Phase 3 leaving a balance of \$108,909. Trail Dedication \$3,155,047 balance.

**CRITICAL ISSUES**: Staff would like the joint meeting to be on May 12 or May 26 City Council Meeting. Staff will need time to assemble any materials required for the meeting.

**BUDGET IMPACT**: None

**RECOMMENDATION**: Discussion only.

**ATTACHMENT(S)**: Diamond Lake Diamonds concept, Trail map.

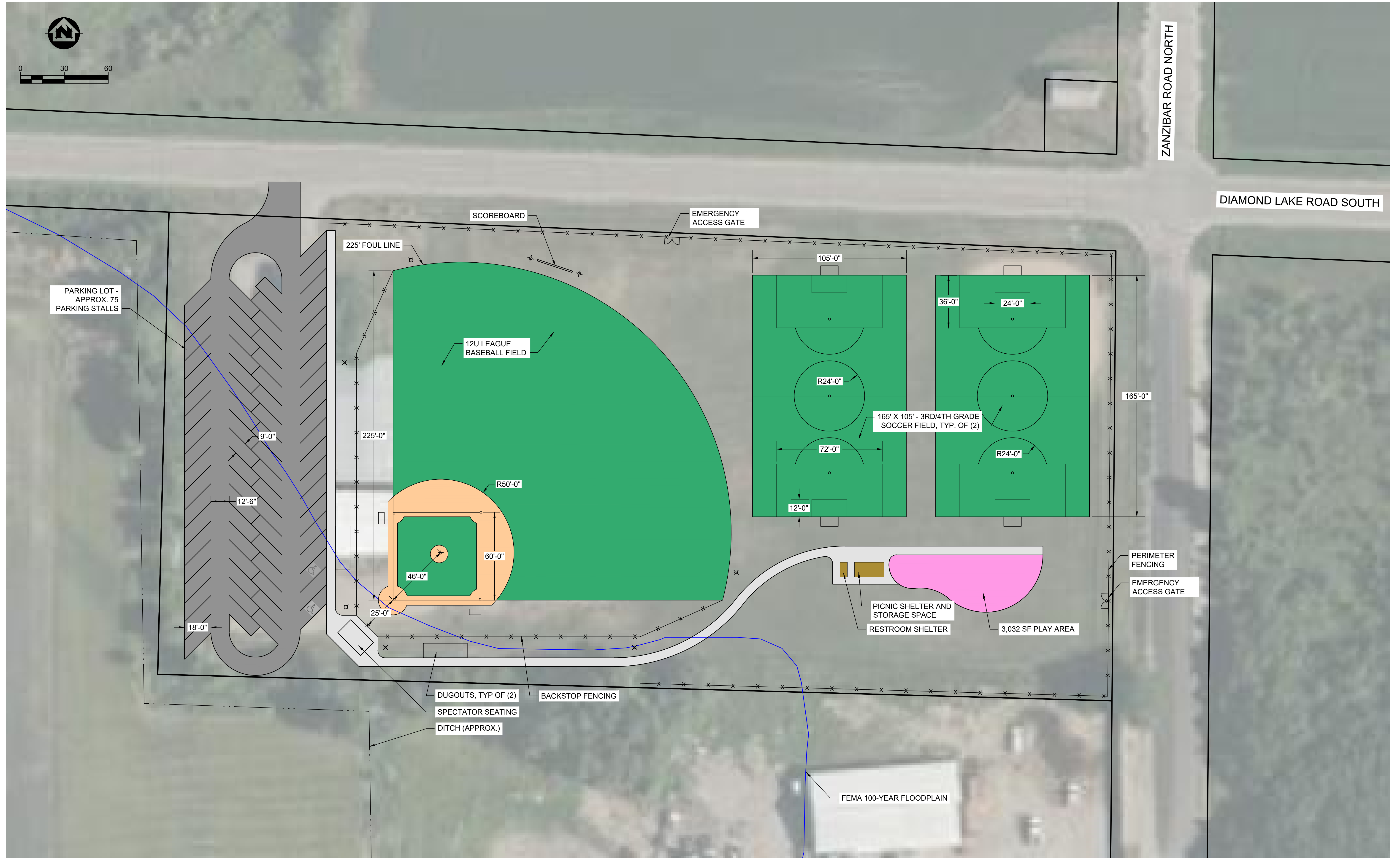
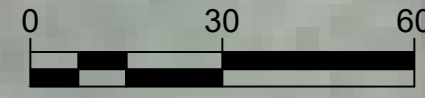

PROJECT DATE:	NO.	DATE	REVISION	BY:
10/7/25	1			
DRAWN BY: KEF	2			
DESIGNED BY: ERB	3			
CHECKED BY: ERB	4			



ENGINEERING | ARCHITECTURE | SURVEYING  
 FUNDING | PLANNING | ENVIRONMENTAL  
 www.msa-ps.com  
 © MSA Professional Services, Inc.

DIAMOND LAKE DIAMONDS  
 DAYTON, MN

CONCEPT B

PROJECT NO.  
12021006  
 SHEET  
C301

PLOT DATE: 11/5/2025 5:03 PM, G:\12\12021\12021006\CADD\C3D\12021006 Design.dwg

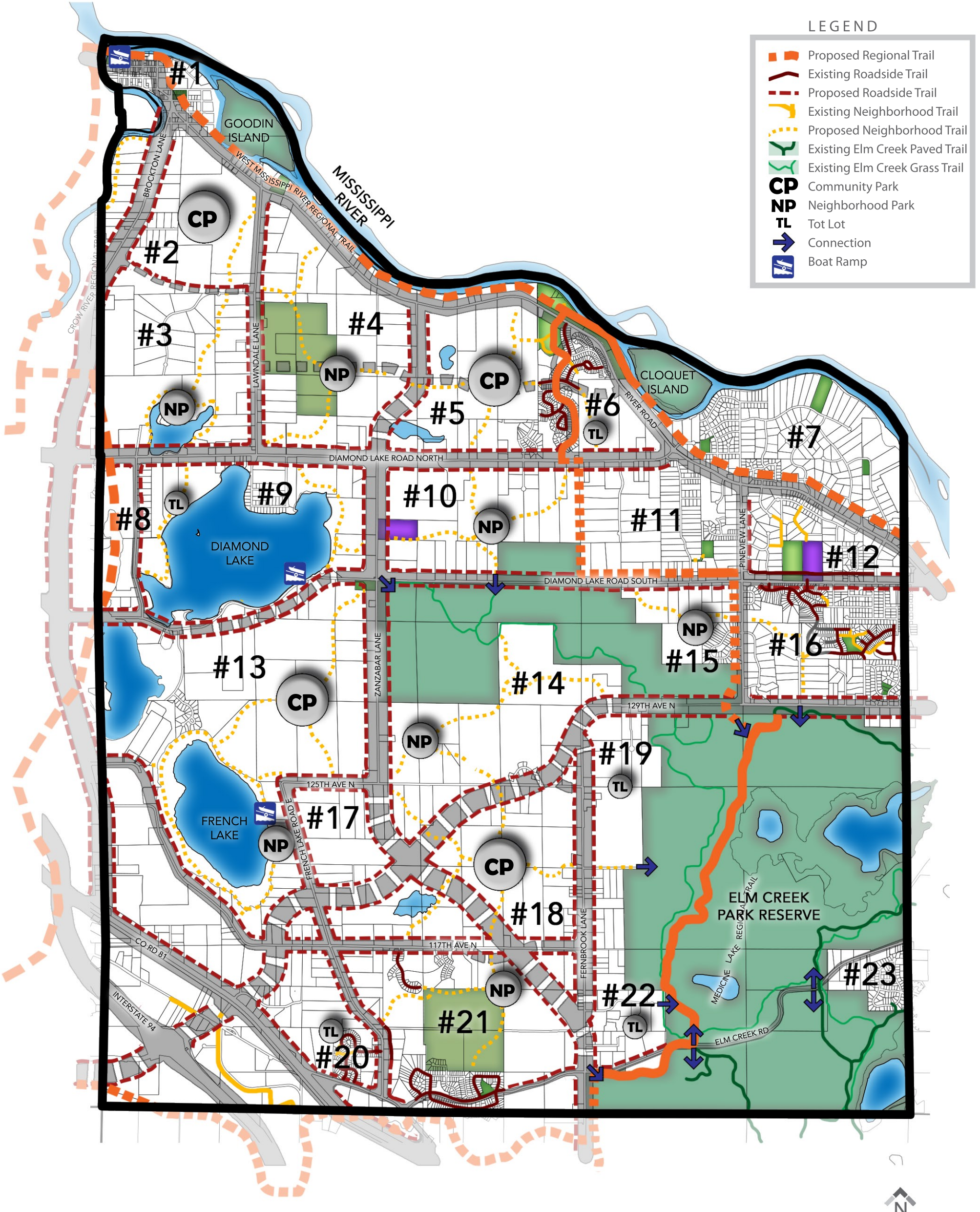

LEGEND

- Proposed Regional Trail
- Existing Roadside Trail
- Proposed Roadside Trail
- Existing Neighborhood Trail
- Proposed Neighborhood Trail
- Existing Elm Creek Paved Trail
- Existing Elm Creek Grass Trail
- CP** Community Park
- NP** Neighborhood Park
- TL** Tot Lot
- Connection
- Boat Ramp



**PRESENTER:** Martin Farrell

**ITEM:** Elsie Stephens Park Master Plan Phase 3

**PREPARED BY:** Martin Farrell

**POLICY DECISION / ACTION TO BE CONSIDERED:** Information and discussion

**BACKGROUND:** The Master Plan for Elsie Stephens Park was an effort developed between 2016 and 2018, with Staff, Council, Contract Landscape Architects, and a Steering Committee. The project was refined over several meetings and with input from all of the participants at the various stages of development. The City is currently in Phase 3 of the development of the Park, with various elements being installed including, trails and river overlooks, landscaping, bridges, performance area with seating and power, patio, decorative lighting, and trail link into Cloquet Overlook Park, part of the Three Rivers Park District Mississippi Regional Trail.

The City Council has requested that future phases be identified along with costs and an approximate timeline for the additional phases. Staff recommended an update of the Master Plan, and conducted an RFP requesting proposal documents from interested Landscape Architects. Staff received 6 proposals, and reviewed each of them for compliance to the RFP and reduced the contenders to 3 finalists for Park Commission to Interview.

City Council Awarded the Contract for the project to MSA at their regular council meeting on 02-25-2025. Since contract award MSA has conducted meetings and data gathering from Staff, Community representatives, Commission & Council representatives, and residents. MSA presented initial Concepts based on the direction given. Concepts were presented at the 9-2-2025 Park Commission meeting for review and comments.

Subsequent to the 9-2-2025 concept presentation, further refinements have been included based on feedback received, we are close to the final version of the concept and are not anticipating major changes to the Concept.

At their 10-07-25 regular meeting, Park Commission reviewed the master plan concept and voted unanimously to recommend the Council adopt the master plan concept.

The master plan was presented to the City Council at the 10-21-2025 meeting, where after discussion the plan was adopted without the phasing suggestions or costings, to provide flexibility in the future development of the Park.

Staff has worked with MSA to refine Councils request for Phase 3 of Elsie Stephens Park development, the Council identified 4 items for inclusion, Bathrooms, Splash Pad, Performance stage improvements, additional parking. A budget of \$1,500,000 was suggested for these improvements. The concept plans for Phase 3 have been reimaged and cost estimated for the project at \$2,025,000, Staff are looking for direction from the Council of how to proceed with Phase 3 of Park Development.

At the 01-27-2026 City Council meeting Staff were directed to prioritize making improvements to the performance area and installing a concrete pad for the dance area. Council also directed

Staff to identify the costs for a Stage cover based on the Council's preferred wave style structure. Council directed staff to purchase the structure and include construction of the structure within the bid package for the remaining aspects of the Phase 3 improvements. Council also directed staff to use a General contractor for the installation of the structure, concrete work, electrical and any Civil Engineering improvements that may be required. The General Contractor will be identified from the bidding procedure for the work on Phase 3A.

Although this appears to be a simple project there are a number of things to be considered

Size and placement of the structure, Staff need to obtain Engineered drawings for the structure before it can be ordered. These drawings will inform the size and placement of the structure, currently it is not known if the existing concrete at the performance area is robust enough to take the weight of the structure plus any snow loads. If it is not strong enough, then the location for the supports will need to be outside of the existing stage, which will increase the size of the structure.

The proposed area for the dance area has the ADA trail going through the middle of the dance floor, so that will need to be relocated, at a grade that is ADA compliant.

Council requested staff gather more information about the splash pad and bathroom facilities to identify the best way forward, given there are multiple factors to be considered with this amenity of the Phase 3 development.

At the 02-24-2026 City Council meeting council requested revised bid from MSA with reduced scope of work and staff to obtain bids from additional contractors for comparison. Staff contacted 2 local contractors and met with them to discuss the project only one of the additional contractors submitted a proposal for the project.

At the 03-24-2026 Council Meeting, council approved MSA to provide bidding documentation for the project. Staff are pursuing pricing and timelines from vendors for the performance area cover. Staff will be presenting options to the Council at the 04-14-2026 meeting to make a decision on the style, and size for the structure so staff can approve Engineered drawings and proceed to production of the structure. Council is anxious to get the structure erected this year.

**CRITICAL ISSUES:** Aligns with Council Goal to "Maintain and Enhance the Natural and Rural Community Connection".

**BUDGET IMPACT:** Funded from Capital Fund 405

**RECOMMENDATION:** None

**ATTACHMENT(S):** Polygon structures and pricing and Fifthroom structures and pricing.

# QUOTATION



Phone: 651-815-4097

10085 Bridgewater Bay  
Woodbury, MN 55129

Email: [info@northlandrec.com](mailto:info@northlandrec.com)

To:  
City of Dayton  
12260 South Diamond Lake Road  
Dayton, MN 55327

Date: 3/12/26  
Contact: Martin Farrell

[Elsie Stephens Park Custom Wave/Beam Ampitheater](#)

Engineered Drawings Lead Time Currently Is 9-11 Weeks  
Production Lead Time Is Currently 10-12 Weeks

NOT Included This quote does NOT include installation of the shelter design or installation of concrete footings, concrete pad, building permits, bonding costs, special inspections, site work, etc

### Site preparation and restoration by others

- \* Quotation is valid for See Above Details
- \* Freight based - shipping to Dayton
- \* Estimated ship date is TBD based upon engineered drawing approval
- \* Terms based on Based on credit approval - downpayment may be required
- \* Orders will be placed upon receipt of Purchase Order made out to **Northland Recreation** or your signed acceptance.

Sub Total	\$261,240.00
Freight	Included
Tax - Exempt	\$0.00
<b>TOTAL</b>	<b>\$261,240.00</b>

Quote By: **Sue Ayers**

**THANK YOU !**

Accepted By: \_\_\_\_\_

Date: \_\_\_\_\_

NOTES: Poligon shelter listed on this quote will be engineered based on this design below. Internal anchor bolts at finished grade. Other anchor bolt layouts are available but may require additional engineering at an additional cost due to post length needed

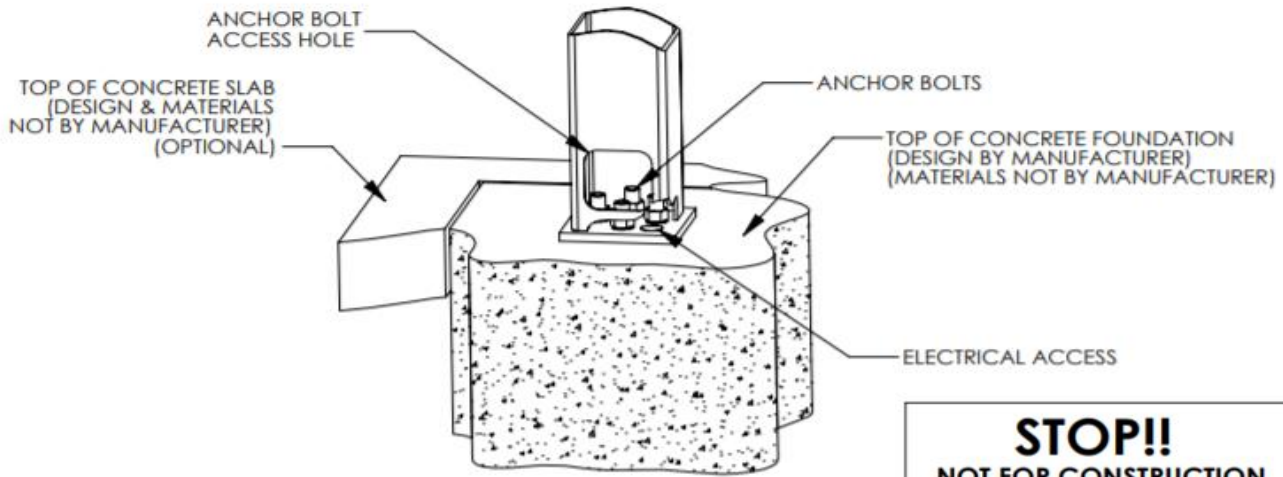

**INTERNAL ANCHOR BOLTS**  
(AT FINISH GRADE)

<b>STOP!!</b> <b>NOT FOR CONSTRUCTION</b>
USE FOR PRELIMINARY PLANNING AND ESTIMATING ONLY

# QUOTATION



Phone: 651-815-4097

10085 Bridgewater Bay  
Woodbury, MN 55129

Email: [info@northlandrec.com](mailto:info@northlandrec.com)

To:  
City of Dayton  
12260 South Diamond Lake Road  
Dayton, MN 55327  
[Elsie Stephens Park Custom Wave Ampitheater](#)

Date: 3/12/26  
Contact: Martin Farrell

QTY	ITEM	DESCRIPTION	UNIT	EXTENSION
-----	------	-------------	------	-----------

**Poligon Custom Wave Ampitheater**

1	WWA	Wood Wave Ampitheater 36'x34' Stained Tongue & Groove Under decking with Multi-Rib Roof 4 Columns, 10' eave height, Roof Pitch 2:12 10' Overhang beyond Columns 8 Electrical Cutouts and Access Poli 5000 Paint System - Standard Color Chart Selection - Columns Wind Speed 110 mph / Ground Snow Load 50lb Cast-In-Place Anchor Rods, Nuts and Template Stamped Engineered Drawings & Shipping to Dayton		
---	-----	--	--	--

Engineered Drawings Lead Time Currently Is 9-11 Weeks  
Production Lead Time Is Currently 10-12 Weeks

NOT	Included	This quote does NOT include installation of the shelter design or installation of concrete footings, concrete pad, building permits, bonding costs, special inspections, site work, etc
-----	----------	---

**Site preparation and restoration by others**

\* Quotation is valid for See Above Details

\* Freight based - shipping to Dayton, MN

\* Estimated ship date is TBD based upon engineered drawing approval

\* Terms based on Based on credit approval - downpayment may be required

\* Orders will be placed upon receipt of Purchase Order made out to **Northland Recreation** or your signed acceptance.

Sub Total	\$116,130.00
Freight	Included
Tax - Exempt	\$0.00
<b>TOTAL</b>	<b>\$116,130.00</b>

Quote By: **Sue Ayers**

**THANK YOU !**

Accepted By: \_\_\_\_\_

Date: \_\_\_\_\_

NOTES: Polygon shelter listed on this quote will be engineered based on this design below. Internal anchor bolts at finished grade. Other anchor bolt layouts are available but may require additional engineering at an additional cost due to post length needed

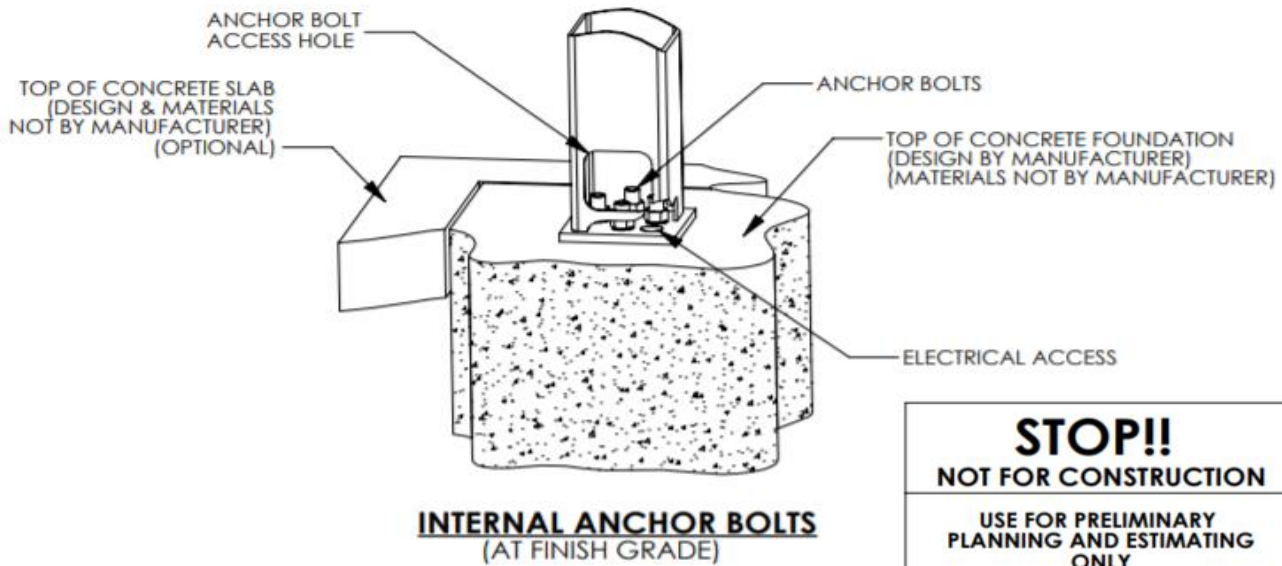



WWA



WBA

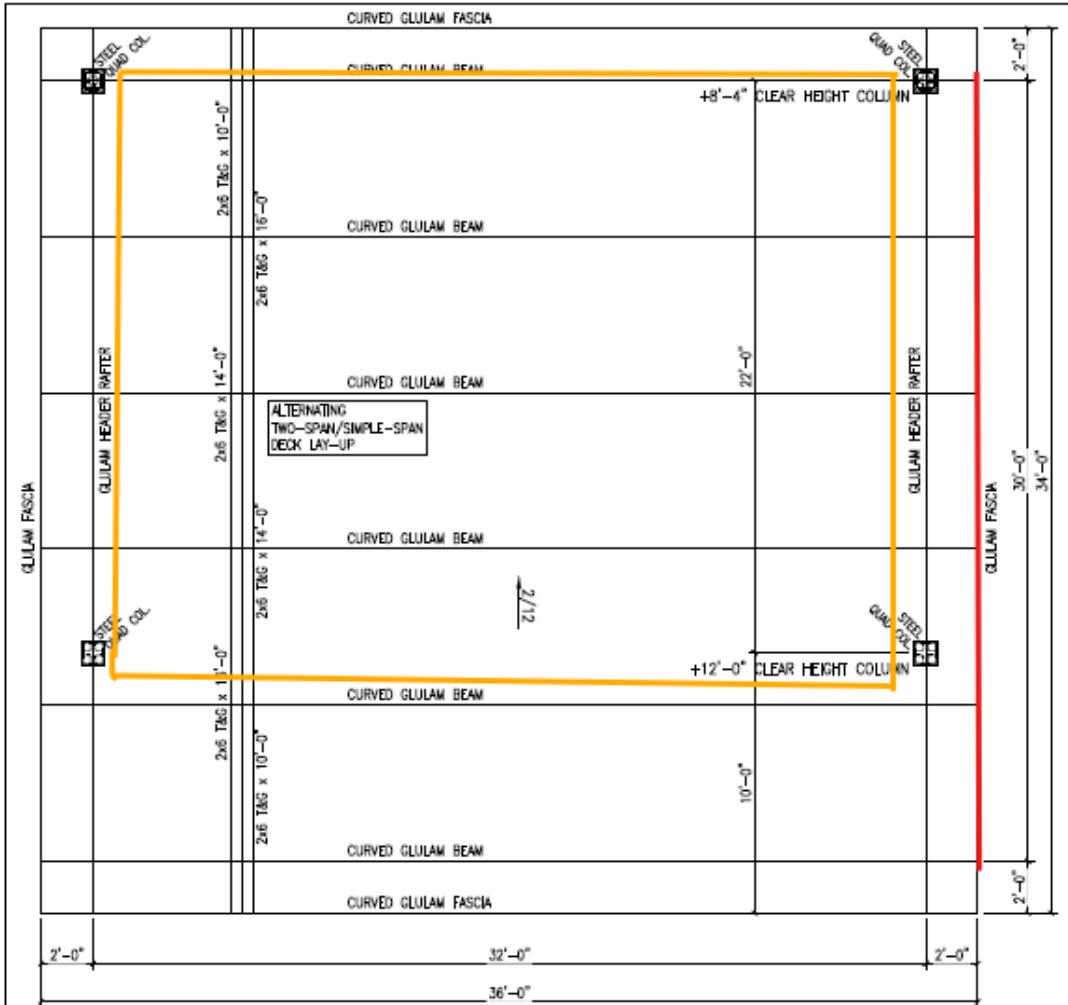

**36'x34' WAVE BAND**  
 $1/4" = 1'-0"$

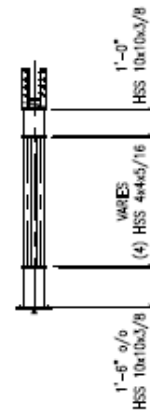
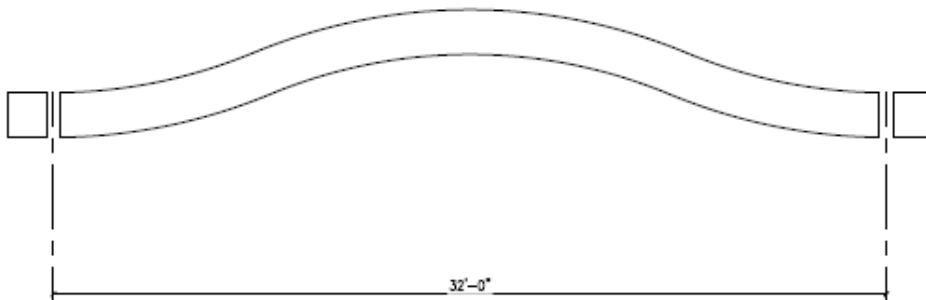

One thing to note is that Poligon cannot design the footings for the structures as they are on such a water table, but, being that we discussed that an engineer should be involved with regards to the retaining wall, ADA walkways, ect at the site, I would recommend getting their expertise on this also. It was recommended that the footings should be at least 5'Wx6'D.

Engineered drawings are currently 9-11 weeks and cost \$2000 for each option requested.

Please let me know if you have any questions and I'll be happy to assist.



Custom pavilions are 3-6 weeks after down payment for drawings.

The next 1/3 with approvals will begin production. Balance paid prior to shipping.

Right now production on these is at 15+ weeks.